

NATURE'S INVISIBLE
SPACE MECHANICS
AS USED IN THE
DESIGN OF
GRAVITY GENERATORS

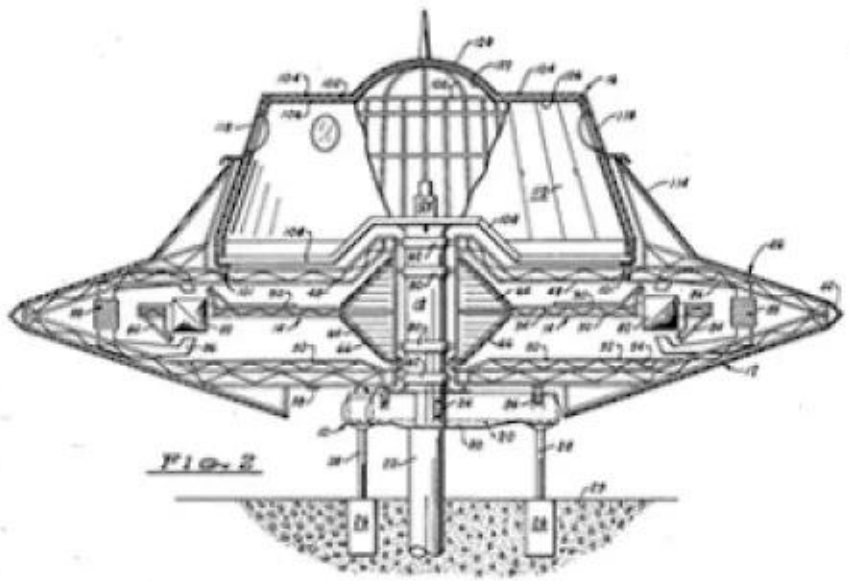

FIG. 2

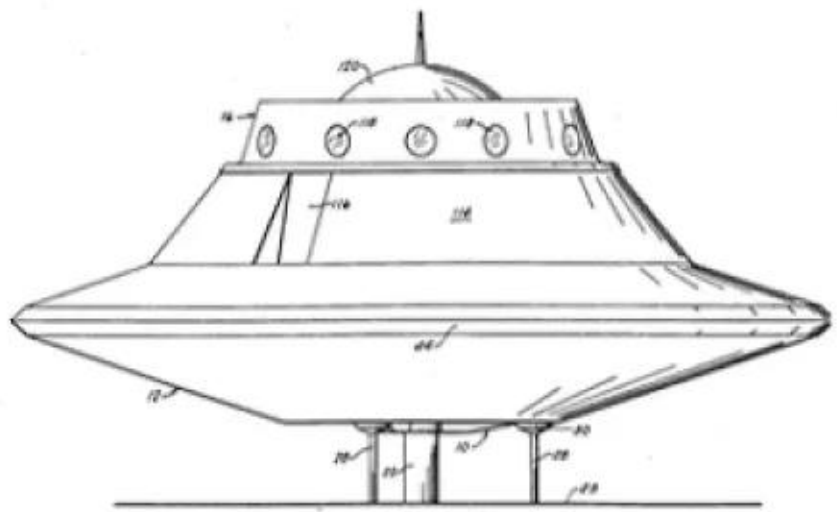
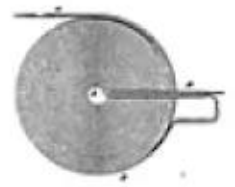

FIG. 1

TESLA PANCAKE SHAPED TRANSFORMER. The windings from the periphery to the center in spiral fashion increases low potential voltage to high potential with much greater efficiency than ordinary cylindrical wound coils.



The UTRON coil from the Carr levity disc experiments has the geometry of space. A coil completely round and at the same time completely square was tested for angle interaction of fields. (See Issue #20 of "Energy Unlimited" for report on gravity experiments)

NOTE: FIELD OF UTRON INTERACTS WITH MAGNETIC FIELD AT 45 DEGREES

UTRON FIELD LINES FROM C-SHAPED MAGNETS



LARGER CAPACITOR DISC INSULATED AGAINST CENTER TUBING

COIL IS MADE OF #40 WIRE, 5.5 INCH LONG, ABOUT 800 OHMS WIRE RESISTANCE WHICH IN THIS CASE RESULTS INTO 750 CPS AND DOMES.

LINEAR COIL PLACED IN A HIGH POTENTIAL ELECTROSTATIC FIELD BY MEANS OF A CAPACITOR AS ILLUSTRATED ABOVE.

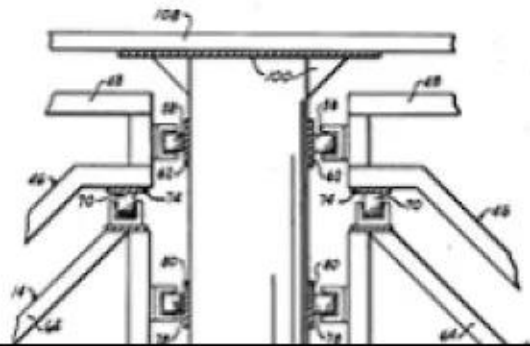
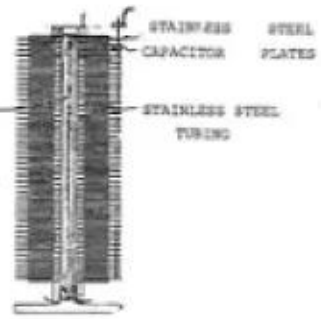
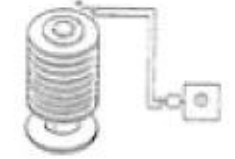
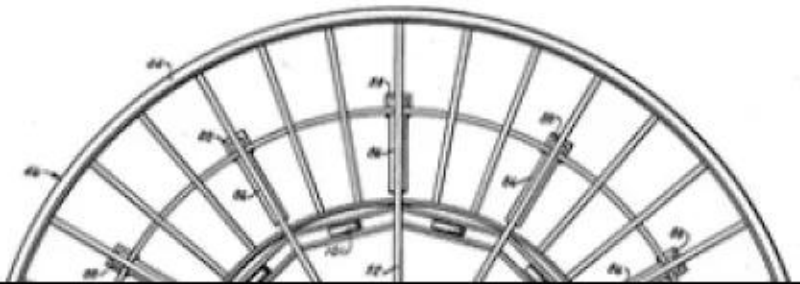

FIG. 2



1
00:00:23,670 --> 00:00:21,830

[Music]

2
00:00:27,029 --> 00:00:23,680

otis t carr

3
00:00:28,550 --> 00:00:27,039

the man who patented a saucer by michael

4
00:00:30,710 --> 00:00:28,560

locke

5
00:00:32,790 --> 00:00:30,720

in the late 1950s

6
00:00:35,510 --> 00:00:32,800

flying saucers had been in the public

7
00:00:37,590 --> 00:00:35,520

consciousness for about a decade the

8
00:00:41,030 --> 00:00:37,600

shock of the arnold sighting and the

9
00:00:44,069 --> 00:00:41,040

ufos over washington dc had worn off

10
00:00:46,389 --> 00:00:44,079

saucers though still mysterious were now

11
00:00:48,709 --> 00:00:46,399

familiar the government was actively

12
00:00:51,910 --> 00:00:48,719

running its third investigation into the

13
00:00:54,069 --> 00:00:51,920

reports of unidentified flying objects

14

00:00:57,189 --> 00:00:54,079

hollywood was incorporating the now

15

00:00:59,349 --> 00:00:57,199

iconic saucer craft into films of all

16

00:01:02,069 --> 00:00:59,359

budgets books had been printed on

17

00:01:04,390 --> 00:01:02,079

saucers and ufo magazines were on

18

00:01:06,550 --> 00:01:04,400

newsstands every week

19

00:01:09,190 --> 00:01:06,560

a new culture was being born around the

20

00:01:11,109 --> 00:01:09,200

flying saucers and the possibility of

21

00:01:13,350 --> 00:01:11,119

alien contact

22

00:01:15,910 --> 00:01:13,360

many people claim to have been contacted

23

00:01:18,469 --> 00:01:15,920

by extraterrestrials and some even

24

00:01:20,070 --> 00:01:18,479

claimed to have ridden in their crafts

25

00:01:21,830 --> 00:01:20,080

others maintained that they had been

26

00:01:24,070 --> 00:01:21,840

given messages for their fellow

27

00:01:26,310 --> 00:01:24,080

earthlings from the space brothers or

28

00:01:28,950 --> 00:01:26,320

the comely venusians out of this

29

00:01:31,749 --> 00:01:28,960

environment came long john nebel and his

30

00:01:35,510 --> 00:01:31,759

party line radio show broadcasting over

31

00:01:37,429 --> 00:01:35,520

six days a week on new york's w-o-r he

32

00:01:39,910 --> 00:01:37,439

often brought together a panel of

33

00:01:42,310 --> 00:01:39,920

commentators from a variety of fields to

34

00:01:44,870 --> 00:01:42,320

help him interview guests

35

00:01:47,429 --> 00:01:44,880

the paranormal was a common focus and

36

00:01:50,469 --> 00:01:47,439

ufos were a favorite topic neville

37

00:01:53,270 --> 00:01:50,479

regularly brought in contactees such as

38

00:01:55,270 --> 00:01:53,280

george van tassel and researchers such

39

00:01:58,550 --> 00:01:55,280

as ivan t sanderson

40

00:02:00,950 --> 00:01:58,560

in april of 1958 longjohn neville

41

00:02:03,910 --> 00:02:00,960

interviewed for the first time otis t

42

00:02:07,030 --> 00:02:03,920

carr the president of otc enterprises

43

00:02:09,029 --> 00:02:07,040

who was marketing his own flying saucer

44

00:02:11,430 --> 00:02:09,039

the first unit would cost 20 million

45

00:02:13,510 --> 00:02:11,440

dollars delivered but subsequent units

46

00:02:16,790 --> 00:02:13,520

would be able to be produced for 4

47

00:02:19,110 --> 00:02:16,800

million each otis t carr was not a

48

00:02:21,830 --> 00:02:19,120

contactee nor did he claim that his

49

00:02:24,790 --> 00:02:21,840

circular foil spacecraft had any alien

50

00:02:26,470 --> 00:02:24,800

technology in its design instead he

51
00:02:29,110 --> 00:02:26,480
claimed that he had taken the work of

52
00:02:31,830 --> 00:02:29,120
nikola tesla the inventor of radio and

53
00:02:33,830 --> 00:02:31,840
proponent of ac power transmission and

54
00:02:36,070 --> 00:02:33,840
developed an entirely new type of

55
00:02:38,550 --> 00:02:36,080
propulsion the utron electrical

56
00:02:40,990 --> 00:02:38,560
accumulator was described by carr as not

57
00:02:43,430 --> 00:02:41,000
a perpetual motion device but a

58
00:02:45,910 --> 00:02:43,440
self-energizing machine that combined

59
00:02:48,790 --> 00:02:45,920
electromotive electromagnetic and

60
00:02:51,270 --> 00:02:48,800
gravity forces in a unified field he

61
00:02:53,589 --> 00:02:51,280
told long john nebel and his panel that

62
00:02:56,550 --> 00:02:53,599
he even corresponded with and was

63
00:02:58,630 --> 00:02:56,560

briefly advised by albert einstein the

64

00:03:01,430 --> 00:02:58,640

craft would operate in both the vacuum

65

00:03:03,990 --> 00:03:01,440

of space and earth's atmosphere offering

66

00:03:06,710 --> 00:03:04,000

speeds and handling superior to any

67

00:03:09,350 --> 00:03:06,720

conventional aircraft best of all

68

00:03:12,390 --> 00:03:09,360

occupants would require neither g suits

69

00:03:15,190 --> 00:03:12,400

or spacesuits the utron powered ship was

70

00:03:17,990 --> 00:03:15,200

to be saucer shaped and 45 feet in

71

00:03:20,630 --> 00:03:18,000

diameter this size was designed to allow

72

00:03:22,470 --> 00:03:20,640

a crew of three to travel in comfort

73

00:03:24,470 --> 00:03:22,480

thanks to a capacitative plate that

74

00:03:26,390 --> 00:03:24,480

would spin counterclockwise while the

75

00:03:28,229 --> 00:03:26,400

body of the ship moved in a clockwise

76

00:03:30,830 --> 00:03:28,239

direction carr maintained that the ship

77

00:03:33,830 --> 00:03:30,840

would enjoy near-earth gravity while in

78

00:03:35,589 --> 00:03:33,840

space the cabin would be pressurized

79

00:03:38,070 --> 00:03:35,599

like a conventional aircraft or

80

00:03:40,229 --> 00:03:38,080

submarine best of all he posited that

81

00:03:42,149 --> 00:03:40,239

his flying saucer would be able to fly

82

00:03:44,710 --> 00:03:42,159

from earth to the moon in only four to

83

00:03:47,030 --> 00:03:44,720

five hours it would also be able to take

84

00:03:48,229 --> 00:03:47,040

longer trips to visit other planets if

85

00:03:50,710 --> 00:03:48,239

desired

86

00:03:53,110 --> 00:03:50,720

although otc enterprises had yet to

87

00:03:55,589 --> 00:03:53,120

build a working prototype cart did bring

88

00:03:57,589 --> 00:03:55,599

equipment models and various brochures

89

00:04:00,630 --> 00:03:57,599

and sales literature to the party line

90

00:04:02,710 --> 00:04:00,640

for panel members to examine among the

91

00:04:04,630 --> 00:04:02,720

materials presented was a utron

92

00:04:07,589 --> 00:04:04,640

electrical accumulator which was a

93

00:04:09,670 --> 00:04:07,599

simple two-piece device carr explained

94

00:04:11,990 --> 00:04:09,680

that he had sent his materials not only

95

00:04:14,229 --> 00:04:12,000

to the atomic energy commission but also

96

00:04:16,870 --> 00:04:14,239

directly to president eisenhower and

97

00:04:18,710 --> 00:04:16,880

other government agencies he also seemed

98

00:04:20,870 --> 00:04:18,720

genuinely surprised that he had not

99

00:04:22,870 --> 00:04:20,880

received a single response from any

100

00:04:26,390 --> 00:04:22,880

level of government

101
00:04:29,270 --> 00:04:26,400
in 1959 otis carr would receive a u.s

102
00:04:31,350 --> 00:04:29,280
patent for his flying saucer although it

103
00:04:33,430 --> 00:04:31,360
was identified as a

104
00:04:35,990 --> 00:04:33,440
amusement device

105
00:04:38,230 --> 00:04:36,000
today the patent drawing is available on

106
00:04:41,110 --> 00:04:38,240
the u.s patent office website under

107
00:04:46,550 --> 00:04:44,710
two us0029 one two two four four

108
00:04:51,270 --> 00:04:46,560
carr would return to long john neville

109
00:04:53,110 --> 00:04:51,280
show again later in 1958 and in 1959

110
00:04:55,430 --> 00:04:53,120
by then he claimed to be ready to

111
00:04:57,110 --> 00:04:55,440
demonstrate his flying saucer so long

112
00:05:00,629 --> 00:04:57,120
john took his show on the road to

113
00:05:02,710 --> 00:05:00,639

oklahoma city in april of 1959 to

114

00:05:04,310 --> 00:05:02,720

witness the maiden flight of carr's

115

00:05:06,550 --> 00:05:04,320

device

116

00:05:09,350 --> 00:05:06,560

at an amusement park called frontier

117

00:05:11,590 --> 00:05:09,360

city the liftoff was to be a simple test

118

00:05:14,150 --> 00:05:11,600

flight in anticipation of a trip to the

119

00:05:16,629 --> 00:05:14,160

moon scheduled for december

120

00:05:19,510 --> 00:05:16,639

carr was to be the pilot and major wayne

121

00:05:22,629 --> 00:05:19,520

ajo another frequent guest of long john

122

00:05:24,550 --> 00:05:22,639

nebel would be co-pilot it was ajo who

123

00:05:26,469 --> 00:05:24,560

had served as a combat intelligence

124

00:05:28,710 --> 00:05:26,479

officer in the army who would be

125

00:05:31,110 --> 00:05:28,720

piloting the ship on its voyage to the

126

00:05:33,270 --> 00:05:31,120

moon in december although carr had

127

00:05:35,110 --> 00:05:33,280

claimed to see flying saucers on three

128

00:05:37,909 --> 00:05:35,120

separate occasions he was not a

129

00:05:39,749 --> 00:05:37,919

contactee he also stated that when he

130

00:05:42,070 --> 00:05:39,759

saw the saucers he felt that they

131

00:05:44,310 --> 00:05:42,080

confirmed his theories but he did not

132

00:05:46,310 --> 00:05:44,320

claim to derive any of his technology

133

00:05:49,430 --> 00:05:46,320

from extraterrestrials

134

00:05:51,590 --> 00:05:49,440

aha though was a contactee who would go

135

00:05:54,550 --> 00:05:51,600

on to organize an effort in the late

136

00:05:56,870 --> 00:05:54,560

1970s to convince president carter to

137

00:05:57,830 --> 00:05:56,880

appoint an official u.s ambassador to

138

00:06:00,230 --> 00:05:57,840

space

139

00:06:02,790 --> 00:06:00,240

the craft never flew

140

00:06:05,189 --> 00:06:02,800

in fact otis carr never even showed

141

00:06:06,950 --> 00:06:05,199

himself at the amusement park he had

142

00:06:09,029 --> 00:06:06,960

been missing in the days leading up to

143

00:06:11,590 --> 00:06:09,039

the launch but was found in a local

144

00:06:13,189 --> 00:06:11,600

hospital by long john nebel on the day

145

00:06:15,270 --> 00:06:13,199

before the launch

146

00:06:17,510 --> 00:06:15,280

in an interview taped in his hospital

147

00:06:19,670 --> 00:06:17,520

room carr stated that even though the

148

00:06:21,749 --> 00:06:19,680

craft was not fully assembled he

149

00:06:24,150 --> 00:06:21,759

expected that it would be launched as

150

00:06:26,710 --> 00:06:24,160

scheduled barring some unforeseen

151
00:06:29,909 --> 00:06:26,720
mechanical or circuit failure the type

152
00:06:31,909 --> 00:06:29,919
of thing he compared to a flat tire

153
00:06:34,309 --> 00:06:31,919
a couple of hours after the ship was

154
00:06:36,309 --> 00:06:34,319
supposed to take off wayne ajo announced

155
00:06:37,990 --> 00:06:36,319
that a mis-engineered bearing would

156
00:06:39,430 --> 00:06:38,000
force the demonstration to be

157
00:06:41,670 --> 00:06:39,440
rescheduled

158
00:06:43,749 --> 00:06:41,680
the party line broadcast dedicated to

159
00:06:46,629 --> 00:06:43,759
cars scheduled maiden flight which

160
00:06:49,430 --> 00:06:46,639
includes both live and taped portions

161
00:06:51,670 --> 00:06:49,440
still survives today in it the prototype

162
00:06:53,909 --> 00:06:51,680
is described in the broadcast as still

163
00:06:55,589 --> 00:06:53,919

being in pieces during a taped visit to

164

00:06:58,150 --> 00:06:55,599

the warehouse where it was stored

165

00:07:00,070 --> 00:06:58,160

shortly before the scheduled flight

166

00:07:02,390 --> 00:07:00,080

although long john nibble seems to have

167

00:07:05,510 --> 00:07:02,400

lost interest in car after the cancelled

168

00:07:07,990 --> 00:07:05,520

demonstration otc enterprises continued

169

00:07:11,430 --> 00:07:08,000

to seek investors and maintain that its

170

00:07:13,830 --> 00:07:11,440

utron technology was legitimate

171

00:07:15,990 --> 00:07:13,840

unfortunately there were those among the

172

00:07:17,830 --> 00:07:16,000

law enforcement community that disagreed

173

00:07:19,909 --> 00:07:17,840

with the stance

174

00:07:23,029 --> 00:07:19,919

carr his director of sales and

175

00:07:25,589 --> 00:07:23,039

engineering norman evans colton and

176

00:07:27,029 --> 00:07:25,599

wayne ajo all eventually were charged

177

00:07:29,670 --> 00:07:27,039

with fraud

178

00:07:31,670 --> 00:07:29,680

aha was exonerated but the others were

179

00:07:33,430 --> 00:07:31,680

convicted

180

00:07:35,909 --> 00:07:33,440

after his conviction

181

00:07:38,790 --> 00:07:35,919

carr faded from the ufo scene and seems

182

00:07:41,589 --> 00:07:38,800

to have passed away in the early 1980s

183

00:07:43,990 --> 00:07:41,599

in pennsylvania although some sources

184

00:07:46,309 --> 00:07:44,000

such as the project camelot webpage on

185

00:07:49,830 --> 00:07:46,319

their interviews with ralph ring state

186

00:07:51,029 --> 00:07:49,840

that he passed away in nevada in 2005 at

187

00:07:54,150 --> 00:07:51,039

which time he would have been

188

00:07:56,629 --> 00:07:54,160

approximately 101 years old

189

00:07:58,950 --> 00:07:56,639

in recent years a man named ralph ring

190

00:08:01,670 --> 00:07:58,960

has surfaced claiming to have once been

191

00:08:03,589 --> 00:08:01,680

a technician in otis carr's employ he

192

00:08:05,909 --> 00:08:03,599

maintained that several models had

193

00:08:09,110 --> 00:08:05,919

actually flown and that a 45-foot

194

00:08:11,830 --> 00:08:09,120

prototype was also successfully flown

195

00:08:13,830 --> 00:08:11,840

ring stated that he had in fact been

196

00:08:16,710 --> 00:08:13,840

part of a three-man crew that made a

197

00:08:18,869 --> 00:08:16,720

near instantaneous journey of 10 miles

198

00:08:21,749 --> 00:08:18,879

in the larger aircraft

199

00:08:23,909 --> 00:08:21,759

unfortunately government agents came and

200

00:08:25,749 --> 00:08:23,919

forced carr's laboratory to shut down

201
00:08:26,950 --> 00:08:25,759
seizing both research notes and

202
00:08:28,869 --> 00:08:26,960
equipment

203
00:08:31,029 --> 00:08:28,879
despite the fact that no scheduled

204
00:08:33,190 --> 00:08:31,039
public launch was ever completed and the

205
00:08:35,909 --> 00:08:33,200
convictions given to both carr and

206
00:08:38,630 --> 00:08:35,919
colton some still believe that his utron

207
00:08:43,560 --> 00:08:38,640
powered circular foil craft was an